

Dynamics of the Photoexcited Electron at the Chromophore–Semiconductor Interface

OLEG V. PREZHDO,^{*,†} WALTER R. DUNCAN,^{†,‡} AND
VICTOR V. PREZHDO[§]

[†]Department of Chemistry, University of Washington, Seattle, Washington 98195,

[‡]Department of Chemistry, Seattle University, Seattle, Washington 98122, and

[§]Institute of Chemistry, Kochanowski University, Kielce, Poland

RECEIVED ON MAY 16, 2007

CON SPECTUS

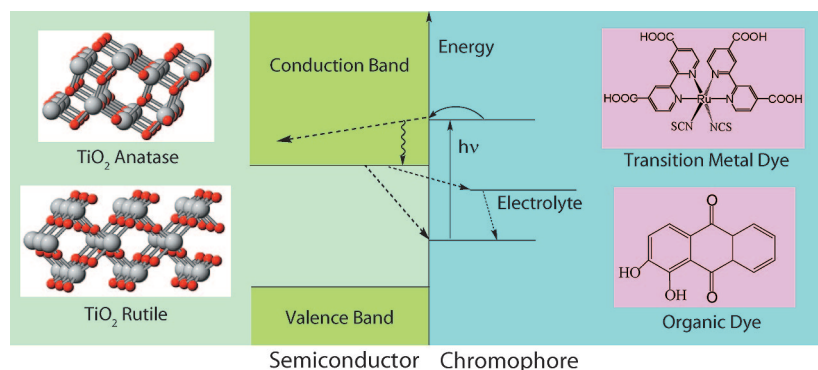

Electron dynamics at molecular–bulk interfaces play a central role in a number of different fields, including molecular electronics and sensitized semiconductor solar cells. Describing electron behavior in these systems is difficult because it requires a union between disparate interface components, molecules and solid-state materials, that are studied by two different communities, chemists and physicists, respectively. This Account describes recent theoretical efforts to bridge that gap by analyzing systems that serve as good general models of the interfacial electron dynamics. The particular systems that we examine, dyes attached to TiO₂, are especially important since they represent the key component of dye-sensitized semiconductor solar cells, or Grätzel cells. Grätzel cells offer a cheap, efficient alternative to traditional Si-based solar cells. The chromophore–TiO₂ interface is a remarkably good target for theorists because it has already been the subject of many excellent experimental investigations.

The electron dynamics in the chromophore–semiconductor systems are surprisingly rich and involve a great variety of processes as illustrated in the scheme above. The exact rates and branching ratios depend on the system details, including the semiconductor type, its bulk phase, and its exposed surface, the chromophore type, the presence or absence of a chromophore–semiconductor bridge, the alignment of the chromophore and semiconductor energy levels, the surface termination, the active vibrational modes, the solvent, the type of electrolyte, the presence of surface defects, etc. Still, the general principles governing the electron dynamics at the bulk–semiconductor interface can be understood and formulated by considering a few specific examples.

The ultrafast time scale of the electronic and vibrational processes at the molecule–bulk interface make it difficult to invoke traditional theories. Instead, we perform explicit time-domain simulations with an atomistic representation of the interface. This approach most directly mimics the time-resolved experimental data and provides a detailed description of the processes as they occur in real time. The simulations described in this Account take into consideration the chemical structure of the system, determine the role of the vibrational motion and non-adiabatic coupling, uncover a vast variety of electron dynamics scenarios, and ultimately, allow us to establish the basic criteria that provide an understanding of this complicated physical process. The insights attained in the theoretical studies let us formulate a number of practical suggestions for improving the properties of the dye-sensitized semiconductor solar cell and for controlling the electron transfer across molecular–bulk interfaces.

Introduction

The transfer of charge through molecules and solid-state structures has been studied separately for many decades, using a variety of experimental techniques and theoretical models. Electron transfer (ET) across molecular/bulk interfaces, however, has become the subject of active research only much more recently. Many details of the interfacial ET remain unknown and are hard to elucidate. These difficulties trace back to the stark differences between the two components of the interface: molecules, which are studied by chemists, and solid-state materials, which are studied by physicists. Molecules, for example, exhibit discrete, localized electronic states, unique vibrational frequencies, and well-defined, directional bonds. Solid-state materials, on the other hand, possess continuous bands of delocalized electronic and vibrational states, can be doped easily, and form defects that disrupt regular bonding patterns. The surface characteristics of solid-state materials are strongly dependent on surface preparation, temperature, and the presence of solvent and other chemicals. The bulk properties can be further affected by quantum confinement effects that depend on the crystal's size. The intrinsic difference between the quantum states of molecules and periodic systems, as well as the often disparate sets of theories and experimental tools used by chemists and physicists,^{1,2} create challenges for the study of the organic–inorganic interface, which plays a key role in many emerging fields.

Designs involving a combination of organic and inorganic components have become increasingly common in recent years, as molecular and solid-state domains have converged, with molecules assembled into ever more complicated mesoscopic structures³ and periodic systems miniaturized on the nanoscale.^{4,5} For instance, interfaces between solid-state and biological systems are encountered in bioanalytical chemistry,⁶ biomechanics,^{7,8} and drug delivery.⁹ Charge transport across the contacts remains the most important area of study in the burgeoning field of molecular electronics;¹⁰ photoinduced electron transfer (ET) at molecular/bulk interfaces constitutes a major focus of research in the chemistry of photoelectrolysis,¹¹ photocatalysis,¹² lithography,¹³ and photography;¹⁴ and molecular/bulk interfacial ET is the primary step in photovoltaic devices,^{15,16} since it allows charge separation upon the absorption of a photon.

A dye coupled to the TiO₂ semiconductor surface is an excellent model for processes that occur in the above fields. This system represents a key part of the Grätzel cell,¹⁷ which is one of the most promising and best-studied alternatives to

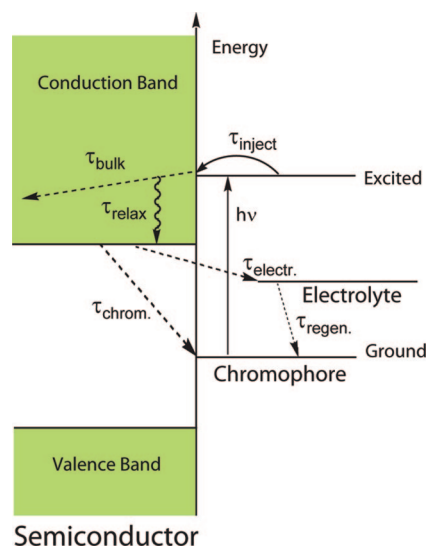

FIGURE 1. Energy diagram of the electronic states participating in the excited electron dynamics at the chromophore–semiconductor interface. The chromophore is excited from its ground state to an excited state that is in resonance with the semiconductor CB. Following a rapid injection into the CB, the electron delocalizes to the bulk and relaxes down in energy to the CB edge. The delocalized electron can return to the semiconductor surface, particularly in the presence of defects in the surface structure and bonding, which create trap states. A photoexcited electron that is close to the surface can be lost by recombination with the positive charge created on the chromophore, by the photoexcitation, or by transfer to an electrolyte molecule. The electrolyte is present in the Grätzel cell in order to regenerate the neutral chromophore by a separate ET event from the electrolyte to the chromophore ground state.

the more costly traditional solar cells made of pure silicon. The conversion of solar energy into an electric current in the Grätzel cell starts with the photoexcitation of the chromophore from its ground state, which is located energetically in the semiconductor band gap, to an excited state that is resonant with the TiO₂ conduction band (CB), Figure 1. After the excitation, an electron is injected from the chromophore to the semiconductor surface, typically on an ultrafast time scale, τ_{inject} . Following the transfer, the electron diffuses into the bulk, τ_{bulk} , simultaneously relaxing to the bottom of the CB and losing its energy to vibrations, τ_{relax} . If the relaxation inside the CB occurs faster than the delocalization into the bulk and the surface contains many defects and unsaturated bonds that support surface states, the electron remains trapped at the surface. The electron that has left the surface can return, since the surface area of the semiconductor is large by design in order to support many chromophores, and since the electron is attracted by the positive charge remaining on the chromophore after the injection. In either case, the surface electron can back-transfer, τ_{chrom} , and recombine with the

hole that exists in the chromophore ground state, thus short-circuiting the cell. Successful cell operation relies on the injected electron's traveling through the semiconductor to an electrode. Having carried a load, the electron makes its way to the other electrode and reacts with an electrolyte. Once the electrolyte molecule approaches the chromophore, the electron is transferred to the chromophore ground state, and the neutral chromophore is regenerated, τ_{regen} . By accepting the surface electron, the electrolyte can also short-circuit the cell, τ_{electr} . This paper considers all of the above processes, each of which occurs at the chromophore–semiconductor interface.

The interfacial processes influence the efficiency of the cell¹⁸ and, therefore, are an object of active investigation, both experimental^{15,17,19–30} and theoretical.^{16,31–43} Two different strategies are used for modeling the interfacial ET in real-time. In one type of study, a simplified model of the interface allows theorists to describe the coupled electron-vibrational dynamics fully quantum-mechanically, to vary the model parameters systematically, and to investigate the influence of various interface characteristics on the ET.^{31–35} The other type of study uses an explicit atomistic representation of the interface combined with quantum-classical or semiclassical electron vibrational dynamics.^{16,36–43} Atomistic simulations treat the interface in realistic detail, including the time-dependent geometric and electronic structure of the chromophore, the surface, and the electrolyte. The same approach considers the binding and chemical bonding between the subsystems, the many-body electronic and electron-vibrational coupling, the solvent, the temperature, and other factors. The discussion presented below deals primarily with the atomistic description of the interface and characterizes its properties and the ET dynamics at the *ab initio* level.

Interface Geometry

The geometric structure of the chromophore–semiconductor interface governs its electronic properties and the ensuing ET dynamics. The properties of the individual constituents of the interface are fairly well understood, although the different communities that discuss them use different terminologies.^{1,2} Chemists concern themselves with dyes, physicists with semiconductors. This discrepancy means that an accurate description of the overall interface remains a challenge. One has to choose a model that combines the periodic properties of the semiconductor with the local molecular structure. A combined model must avoid an unphysical redistribution of charge and spin between the two components, provide stable binding in both chemisorption and physisorption regimes, and be internally consistent in general.

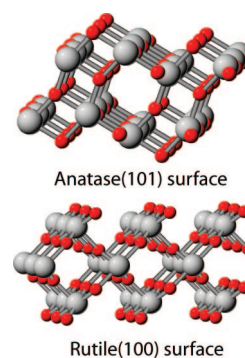

FIGURE 2. Structures of the most common rutile (110) and anatase (101) bare surfaces of the TiO_2 semiconductor. The oxygens (smaller red spheres) terminating the surface interact with chromophores and water. Two types of oxygens are seen. Those oxygens protruding from the surfaces have unsaturated bonds and are chemically reactive. The bridging oxygens located between surface titaniums (bigger gray spheres) have no dangling bonds and can interact with the adsorbed species via hydrogen bonding.

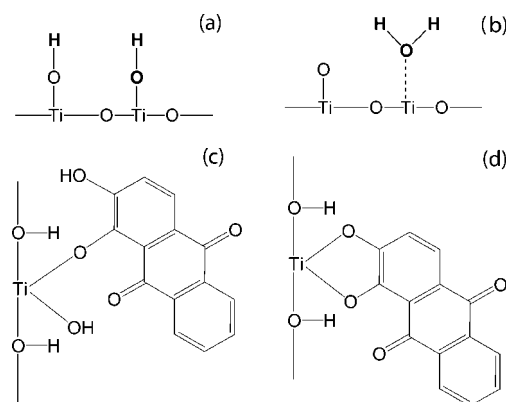

FIGURE 3. Typical patterns of adsorption of water and chromophores on a TiO_2 surface: (a) dissociative adsorption of water; (b) molecular adsorption of water; (c) monodentate binding of alizarin; (d) bidentate binding of alizarin. Water adsorbed on the surfaces is shown in parts a and b in bold.

The TiO_2 semiconductor has a long history in photoelectrochemistry.¹² With few exceptions, the majority of the experimental studies of the interfacial ET in the dye-sensitized TiO_2 systems are carried out with TiO_2 particles that are a mixture of the rutile and anatase crystal forms of TiO_2 with a variety of exposed surfaces.⁴⁴ Bare TiO_2 surfaces, Figure 2, are highly chemically reactive and will interact with those substances that are present in solution and in air. Under high vacuum, the surface will reconstruct in order to saturate the dangling bonds as much as possible. Water adsorbs on TiO_2 both dissociatively and in the molecular form, as depicted schematically in Figure 3, depending on the type of the surface, the presence of defects, the coverage level, the temperature, and other factors.^{16,44} In the absence of efficient hydrogen bonding or other specific interactions, larger molecules containing hydroxyl groups, such as alcohol solvents or sensitizer chro-

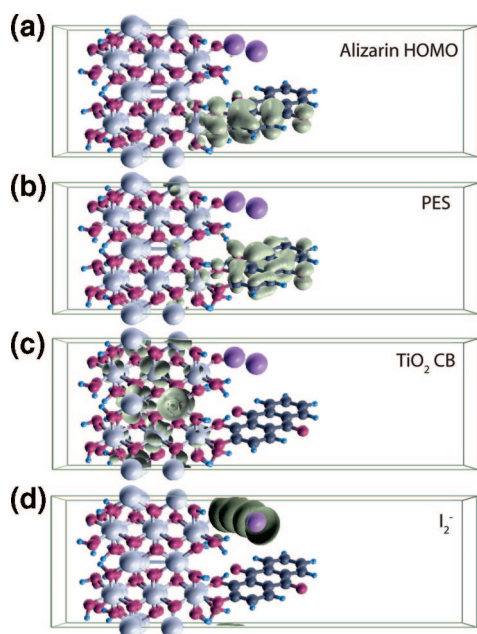

FIGURE 4. The simulation cell and spatial densities of the electronic states that participate in the photoexcited electron dynamics: (a) alizarin ground state; (b) alizarin photoexcited state; (c) TiO₂ CB state; (d) I₂⁻ singly occupied state. The atoms are denoted as follows: Ti, big light gray; O, red; C, dark gray; I, big purple; H, small blue. The semiconductor surface is terminated by a layer of dissociatively adsorbed water. One of the water molecules is replaced by alizarin. The I₂⁻ species replaces an OH⁻ group.

mophores, can be expected to adsorb dissociatively. Chromophore molecules that provide multiple binding groups, such as alizarin with its two hydroxyls, can span more than one Ti atom, Figure 3. In many cases, it is correct to assume that the chromophore geometry is not altered by the binding. In some cases, particularly those involving bidentate binding, the chromophore may be somewhat distorted in order to provide a better match with the surface geometry.⁴⁵ The redox mediator does not permanently bind to the semiconductor surface, since it shuttles between the surface and the counter electrode.

Electronic Structure of Interface

Understanding the electronic properties of the interface is a key prerequisite for studying the electron dynamics. In order to characterize the ET rates and mechanisms, one needs to understand the energy alignment and electronic coupling between the chromophore and semiconductor states. This means developing the static electronic structure picture and considering the coupling of the electronic states that is caused by the vibrational motions at finite temperatures. Electronic structure calculations indicate that the CB of TiO₂ is created by the d-orbitals of the titanium atoms. The gap between the valence and conduction bands of bulk TiO₂ is 3.2 eV, with the

bottom of the CB about 4.5 eV below the vacuum level.¹² The surface induces substantial changes in the bulk electronic structure; localized surface states appear both within the bands and in the gap, and the dangling bonds of an unsaturated surface introduce gap states that can lower the gap energy to a few tenths of an electronvolt. Surface reconstruction partially reopens the gap. Saturation of the surface by chemical bonding of water and other species brings the gap closer to the bulk value.

The chromophores that are used in the chromophore-sensitized TiO₂ photovoltaic cell harvest visible light and are selected to match the semiconductor energy levels and to be photochemically and thermally stable.⁴⁶ They fall into two broad categories: purely organic conjugated molecules, such as alizarin, Figure 3, and transition-metal/ligand complexes.^{15,16} In the complexes, the photoactive ligands are smaller organic conjugated molecules. The photoexcited states formed by the π^* -orbitals of the conjugated systems are similar in both chromophore types. The ground state of the purely organic chromophores is also a π -state, but the ground state of the transition metal chromophores is localized on the n-orbitals occupied by the metal's lone electron pairs. The photoexcitation of a transition metal chromophore gives an intramolecular charge transfer of the n- π^* type. The minor differences between the photoexcited states of the organic and transition metal chromophores result from the larger excited state delocalization in the purely organic chromophores, as well as from the positive charge on the transition metal that slows down the transfer of the electron into the semiconductor. Additional complications with the transition metal chromophores arise from the strong spin-orbit coupling⁴⁷ that provides a high probability of intersystem crossing from the photoexcited singlet into a lower energy triplet state, which may lie below the semiconductor CB and slow down the electron injection.¹⁵

The thermal energy of atomic motion can have a dramatic effect on the geometric and electronic structure of the interface. The binding energy of water and electrolyte molecules to the surface may be weaker than $k_B T$, and a structure that is stable at 0 K can be substantially perturbed at a finite temperature. Thermal fluctuations in the atomic coordinates influence the electronic energy levels, primarily those of the localized states of the chromophore and the electrolyte, Figure 5. The fluctuation of the molecular states closer and farther away from the CB edge, as well as between the regions of higher and lower CB state density, affects the ET reaction rates and mechanisms and creates an inhomogeneous distribution of initial conditions. The low-frequency motions mod-

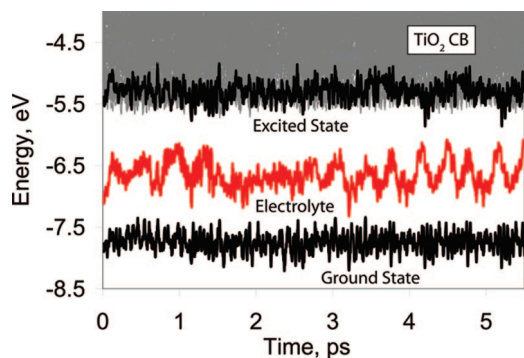

FIGURE 5. Evolution of the electronic state energies along a MD trajectory. The energies fluctuate due to atomic vibrational motions. The CB states of TiO_2 are delocalized over many atoms and, therefore, are least sensitive to local atomic displacements. The oscillation of the alizarin excited state energy near the edge of the CB has a strong effect on the electron injection dynamics. The state localized on I_2^- oscillates with the largest amplitude.

ulate the relative positions of the energy levels, while the higher frequencies determine the electron–phonon coupling that drives the photoexcited electron dynamics.

Injection from Chromophore to Semiconductor

In order to illustrate the features of the electron injection process that become apparent from the time-domain *ab initio* simulations, we consider the alizarin– TiO_2 system that has been studied experimentally^{26–28} and is shown in Figure 4. The chromophore photoexcited state is energetically close to the TiO_2 CB edge, Figure 5. Efficient injection at the band edge produces nontrivial dynamical effects and avoids the voltage loss associated with the relaxation of electrons that are injected higher in the CB. The results of the simulations^{40–43} agree well with the experimental time scales^{27,28} and indicate that the photoinduced ET from a molecular donor to the semiconductor substrate can involve a variety of processes and different ET mechanisms.

Thermal fluctuations of atomic coordinates produce a distribution of the photoexcited state localizations and energies, Figure 5, creating an inhomogeneous ensemble of initial conditions for the electron injection. In some instances, the photoexcited state is well localized on the chromophore. In other cases, over half of the photoexcited state density is on the semiconductor. As a result, on average the electron is 30% delocalized onto the semiconductor. Therefore, the ET coordinate shown in Figure 6 is advanced beyond zero at the initial time. The rest of the injection process takes about 10 fs.

The ultrafast electron injection timescale makes it difficult²¹ to invoke traditional ET descriptions, such as the Marcus model,^{15,24} which assume that vibrational energy redistribu-

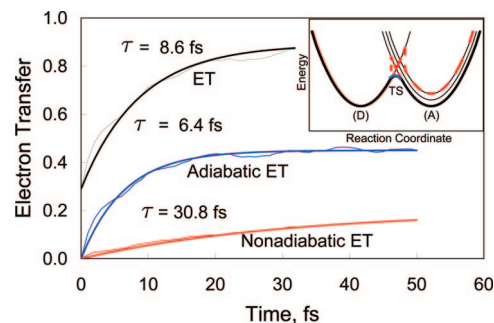

FIGURE 6. The average evolution of the ET coordinate for the electron injection from alizarin into TiO_2 , including the contributions from the adiabatic and NA injection mechanisms. The difference between the two mechanisms is illustrated in the inset, which show two intersecting parabolas representing the electron donor and acceptor state in the Marcus picture of ET. During adiabatic transfer (blue) the electron always remains in the same adiabatic state (the lowest energy state in the inset) and transfers from the donor to the acceptor by crossing a transition state energy maximum. The NA transfer (red) is akin to tunneling, does not require a transition state, and occurs via a quantum transition, or hop, between the donor and acceptor states.

tion occurs faster than the electron dynamics. This fact creates the need for the explicit time-domain simulations. The language of ET theories can still be applied to the interfacial electron injection. In particular, one can distinguish between the adiabatic and nonadiabatic (NA) transfer mechanisms.^{16,24} Either mechanism can, in principle, explain the ultrafast injection. However, the two mechanisms have drastically different implications for the variation of the interface conductance and solar cell voltage with the system properties. In the adiabatic mechanism, the coupling between the dye and the semiconductor is large, and ET occurs through a transition state (TS) along the reaction coordinate that involves a concerted motion of nuclei, see the inset in Figure 6. A small TS barrier gives fast adiabatic ET. Since the adiabatic mechanism relies on strong chromophore coupling to one or a few semiconductor states, the injection can occur close to the edge of the CB, where the density of states (DOS) is low. As a result, energy and voltage may be saved by avoiding the relaxation inside the CB that is inevitable if the electron is injected high into the CB. NA effects decrease the amount of ET that happens at the TS but open up a new channel involving direct transitions from the dye into the semiconductor that can occur at any nuclear configuration. The NA injection rate is proportional to the acceptor DOS;¹⁵ hence, efficient NA injection is possible only high into the CB, resulting in voltage loss. On the other hand, the weak chromophore–semiconductor coupling that is responsible for the NA injection reduces the rate of transfer of the injected electron back onto the chromophore, improving the overall current. The different dependence of the

photovoltaic current and voltage on the chromophore–semiconductor coupling creates a delicate balance that allows for a variety of optimization possibilities.

Delocalization into Semiconductor Bulk

Following the photoexcitation and injection across the chromophore–semiconductor interface, the electron evolves inside the semiconductor both spatially and energetically. The TiO₂ surface state that accepts the injected electron is localized within the first few surface layers.^{40,41} In some cases,^{38,39} a single Ti atom can constitute 20% of the acceptor state density. Simulations⁴¹ indicate that the electron leaves the surface region and delocalizes into the semiconductor bulk on a 100 fs time scale, in agreement with the available experimental data.⁴⁸ The ET from the surface to the bulk occurs in a sequence of NA electronic transitions starting at the surface state. Generally, the delocalization process is not uniform in space but rather exhibits preferential directions, which depend on the symmetry of the photoexcited state.³⁶

Relaxation to the Bottom of the Conduction Band

Simultaneously with the delocalization, the injected electron loses its energy to phonons and relaxes to the bottom of the CB. The relaxation time scale is largely independent of how high in the CB the electron has been injected, Figure 7, indicating that transfers between energetically separated states make a strong contribution to the movement of the electron downward through the band. As much as half an electron-volt of energy can be lost in a single hop, see inset in Figure 7a. Still, the majority of the hops induce only small energy changes, as emphasized by the exponential decay of the probability distribution. The energy flow between the electronic and vibrational degrees of freedom of the semiconductor is not unidirectional. Occasionally, phonons can impart some energy onto the electron. The likelihood of a gain in the electron energy is, however, significantly smaller than the likelihood of an energy loss, especially for large energy hops. The relaxation creates a quasi-equilibrium distribution of state populations near the bottom of the CB.

Back-Transfer to Chromophore

Due to the high surface area of chromophore-sensitized TiO₂, an electron delocalized in bulk TiO₂ has a high probability of finding a surface. Once at the surface, the electron will interact with those chromophores that are still positively charged after the injection and with the electrolyte that has approached the surface. Surface structural defects, such as missing atoms,

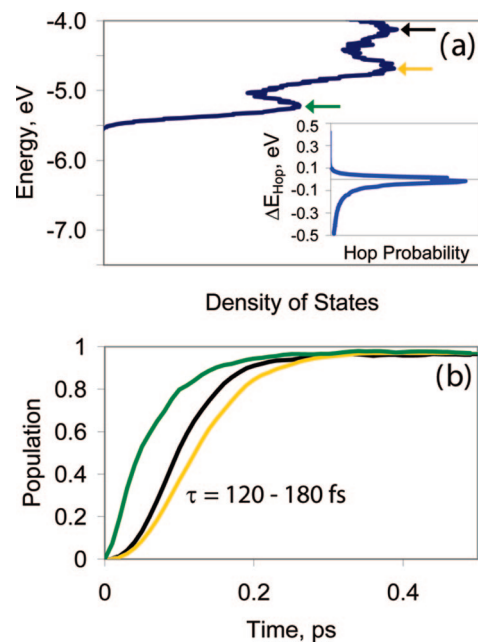

FIGURE 7. Relaxation of the electron injected into the TiO₂ CB. Part a shows the CB DOS with the arrows indicating several injection energies corresponding to the DOS local maxima. The inset in part a gives the probability distribution of the hop energy. Part b shows the time-dependent population of the states within $k_B T$ of the CB edge. The relaxation time scale is essentially independent of the injection energy.

edges, and unsaturated bonds, support trap states with energies below the CB edge. If the electron finds a trap, it will remain at the surface for a long time, increasing the probability of its recombination with the chromophore or electrolyte. Assuming that the electron is trapped inside the first five surface layers, as represented by the simulation cell in Figure 4, the simulation shows⁴³ that the back-transfer to the ground state of alizarin is 2 orders of magnitude slower than the injection⁴¹ and occurs on a picosecond time scale, Figure 8. The result is in agreement with the experimental data.^{26,28}

The recombination of the electron with the chromophore takes place via a NA electronic transition in which a large amount of energy is exchanged between the electron and the phonons. Simulations show that the transition is most efficiently facilitated by the mid-range frequency vibrational modes of the chromophore.⁴³ These modes couple to the electronic states and provide a good match between the electronic and vibrational quanta of energy that are exchanged during the transition. The high-frequency modes that involve the light hydrogen atoms of the C–H chromophore bonds and the O–H groups terminating the semiconductor surface do not take part in the electron back-transfer, since the chromophore and semiconductor electronic states that are engaged in the transition are localized on the heavy atoms.

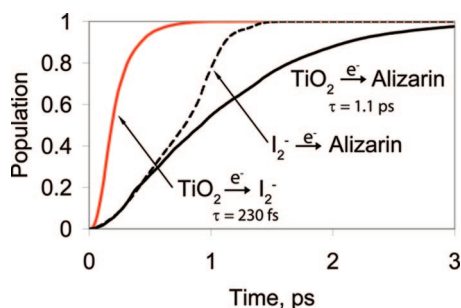
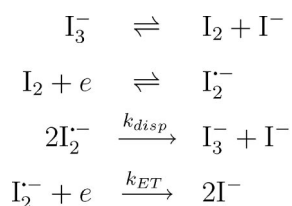

FIGURE 8. Time-dependent populations of the alizarin ground state describing back-ET from the TiO₂ CB to alizarin (black solid line), the I₂⁻ state describing the electron loss from the TiO₂ CB to the electrolyte (red solid line), and the alizarin ground states describing regeneration of the neutral chromophore by ET from the electrolyte (black dashed line). The ET from I₂⁻ to alizarin is nonexponential and is strongly modulated by the orientation and distance between the two species.

Electron Loss to Electrolyte

The I⁻/I₃⁻ redox pair is the most typical Grätzel cell mediator. It acts according to the following mechanism.⁴⁹



The I₂^{•-} radical anion can both donate an electron to the positively charged chromophore and accept an electron from the semiconductor. In order to preserve the overall electro-neutrality, I₂^{•-} replaces an OH⁻ group at the surface, Figure 4. However, it is too large to fit into the space vacated by OH⁻. Instead, it interacts most strongly with the positively charged surface hydrogens and hovers close to the surface. The I₂^{•-}-TiO₂ interaction is sufficiently strong to overcome thermal kinetic energy and maintain surface binding at room temperature. Even though both iodine atoms in the electrolyte molecule have partial negative charges, one of the atoms makes a closer approach to the surface. The diatomic molecule becomes polarized by the surface interaction and is tilted with respect to the surface, Figure 4. An analysis of the processes involving the electrolyte becomes much more complex if one explicitly considers solvent effects.^{50,51}

The energy of the singly occupied orbital of the I₂^{•-} radical anion is located below the TiO₂ CB edge and above the ground state of the chromophore, Figure 5. Since the I₂^{•-} state is closer in energy to the TiO₂ CB than is the chromophore ground state, the electron transfer from the semiconductor is faster to the electrolyte than to the chromophore, so long as the electrolyte molecule is able to approach the surface and

create strong orbital overlap, Figure 8. The time scale for the injected electron to transfer to the electrolyte is largely independent of the injected electron energy. Since the relaxation in the band occurs generally faster than the transfer to I₂^{•-}, compare Figures 7 and 8, the majority of the transfer events occur from the TiO₂ states near the bottom of the CB. Once on I₂^{•-}, the electron has little chance to hop back into the TiO₂ CB; the energy gap is too large to be overcome at room temperature. Thus, the electrolyte can efficiently scavenge the photoexcited electron, provided that both the electron and the electrolyte mediator approach each other near the TiO₂ surface. Due to the presence of both chromophores and electrolyte at the semiconductor surface, surface defects that trap the photoexcited electron provide a very powerful route for electron loss and should be avoided as much as possible.

Transfer from Electrolyte to Chromophore

In the Grätzel cell, the positive charge created on the chromophore by the photoinduced electron injection into the TiO₂ surface is quenched with the negative charge that is brought to the chromophore by the redox mediator. The two species are charged oppositely, and thus they attract each other electrostatically. Since the chromophore is chemically bonded to the semiconductor, the electrolyte-chromophore interaction occurs near the surface, Figure 4. The rate of the ET between I₂^{•-} and alizarin is determined by the electron donor-acceptor coupling, which must be substantially weaker for the spatially separated molecules than for the alizarin-TiO₂ surface donor-acceptor pair, which is chemically bound. Indeed, the nonexponential rise of the occupation of the alizarin ground state seen in Figure 8 indicates that the ET strongly depends on the chromophore-mediator distance. The step in the state occupations seen in the figure is related to the slow-frequency wagging motions of alizarin and I₂^{•-} relative to the surface.⁴³ These motions bring the two species alternatively closer to and farther from each other. An additional channel for ET from I₂^{•-} to alizarin is provided by the binding of both species to the TiO₂ surface. Electronic structure calculations support the existence of the through-bond coupling channel by showing increased delocalization of the I₂^{•-} state density onto the surface in the combined system.⁴³

Summary of the Photoexcited Electron Kinetics

The variety of pathways that are available to the electrons at the chromophore-semiconductor interface are summarized in Figure 9. The time scales reported in the figure are based on the alizarin-TiO₂ system, Figure 4, studied by a combination

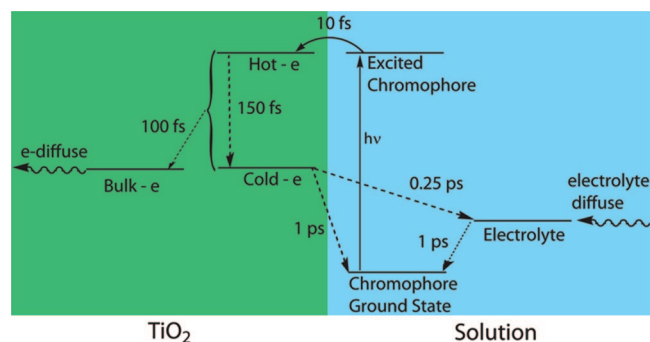

FIGURE 9. Kinetic pathways of electrons near the chromophore–semiconductor interface. The described electron dynamics are initiated by chromophore photoexcitation. The chromophore is chemically bound to the semiconductor. Both electrons in the TiO₂ CB and those in electrolyte molecules in solution can diffuse towards and away from the interface. The reported time scales are based on the alizarin–TiO₂ simulation (see Figure 4) and vary depending on the details of a given system.

of experimental^{26–28} and theoretical^{40–43,52,53} techniques. Other systems can be characterized by the same kinetic scheme with somewhat different time constants. It should be emphasized that the results have been obtained for the situation in which the electrolyte molecule has diffused into a close proximity to the surface.

Comparing the relevant time scales, one concludes that in the absence of trap states, the majority of the injected electrons move away from the surface. However, if the electron is trapped near the surface or repeatedly returns to the surface in a system with a large surface area, it can return to the chromophore and fill in the ground state vacancy. In photovoltaic applications, the relaxation of the electron inside the CB is responsible for voltage loss, and the electron's return to the chromophore decreases solar cell current. The current is also decreased by ET from the semiconductor surface onto the electrolyte. The simulations indicate that if the electrolyte molecules are allowed to chemisorb onto the surface, the photovoltaic device will be very inefficient.

All processes considered in Figure 9 occur by the NA mechanism, Figure 6, involving quantum-mechanical transitions or tunneling between electronic states. The electron injection is the only possible exception. If the chromophore is bound to the semiconductor by a short bridge, the injection happens by the adiabatic mechanism, facilitated by a concerted classical-mechanical motion of chromophore and semiconductor atoms.

Concluding Remarks

The details of the interfacial electron dynamics described in this Account have become available through recent theo-

retical advances in NA molecular dynamics.^{53–55} Time-resolved simulations are of particular value for elucidating the ultrafast ET processes that show a variety of individual events with well-defined dynamical signatures, such as the rise and fall of intermediate state populations, large transient fluctuations from the average behavior, time dependence of the quantum transition rates, and local vibrational heating and cooling. An *ab initio* description of the interface creates an intuitive picture that appeals to chemists and creates a clear understanding of the effects of atomic structure, binding, chemical functionalization, and electronic interactions that occur through bonds and through space. Time-resolved *ab initio* simulations are still rare and are computationally demanding. The field is rapidly progressing though, and state-of-the-art techniques for the dynamics simulations are being actively developed. As the theoretical research advances, larger systems and longer time scales will become accessible, allowing one to probe more examples and finer details of chemical dynamics.

The authors are indebted to many experimentalist and theoretician colleagues for fruitful and illuminating discussions, particularly to Tim Lian, Arthur Nozik, Frank Willig, Josef Wachtveitl, Victor Batista, Haobin Wang, Michael Thoss, and Volkhard May. The research was supported by NSF Awards CHE-0094012 and -0701517, DOE Award DE-FG02-05ER15755, and ACS PRF Awards 150393 and 41436-AC6.

BIOGRAPHICAL INFORMATION

Oleg Prezhdo obtained a Diploma in Theoretical Chemistry in 1991 from Kharkov National University, Ukraine, working on many-body electronic structure theory and electron-vibrational relaxation under Anatoly Luzanov and Yuriy Pedash. From 1991 to 1993, he developed a continuum model of molecular solvation in collaboration with Stanislav Tyurin in Kharkov Polytechnic University. Having moved to the U.S.A. in the fall of 1993, he completed his Ph.D. on “Quantum-classical approaches for simulation of non-adiabatic chemical dynamics in solution” under Peter Rossky at the University of Texas at Austin in 1997. After a brief postdoctoral fellowship with John Tully at Yale, where he worked on constrained density-functional theory for electron transfer, he became an Assistant Professor at the University of Washington in Seattle in 1998. In 2002, he was promoted to Associate Professor and in 2005 to Full Professor. His current research interests range from the fundamental aspects of quantum, classical, and semiclassical dynamics to photoexcitations in quantum dots, carbon nanotubes, molecule–semiconductor interfaces, and ozone layer to order–disorder transitions in electro-optic polymers and to the biological catch-bond.

Walter Duncan received his B.S. in Chemistry in 1995 from Carnegie-Mellon, working with James Whittaker on synthesizing a compound designed to mimic the active site of galactose oxidase. After

a period of relief work in the mountains of Nicaragua, he continued his studies in the Inorganic/Organic division at the University of Oregon. There he worked with David Tyler, exploring solvent cage effects and constructing a time-resolved pump probe laser apparatus. He completed his M.S. in 2000. At the University of Washington, he shifted his focus to Physical Chemistry and worked with Oleg Prezhdo using nonadiabatic molecular dynamics to model electron transfer at organic/inorganic interfaces. He received his Ph.D. in 2007 and is presently a Visiting Professor at Seattle University.

Victor Prezhdo received his Ph.D. at the Kharkov Polytechnic University, Ukraine, in 1970, focusing on intermolecular interactions of molecular complexes in condensed phases. From 1973 to 1977, he was a Docent at the Department of Physical Chemistry, and from 1977 to 1993, he Chaired the Department of Organic Chemistry and Headed the Electro-Optical Laboratory. In 1987, he became a Doctor of Science by habilitation in the Physical Chemistry Institute of the Russian Academy of Sciences in Moscow, with the D.Sc. dissertation title "Intermolecular interactions and electric properties of molecules". In 1993, he moved to Poland where he served as a Visiting Professor at the University of Opole and, in 1996, at the Pedagogical University of Kielce. In 1997, he obtained the Polish Title of Professor of Chemistry by the second habilitation. A member of the Ukrainian, Russian, and Polish Chemical Societies, he published 10 books and over 200 papers and supervised a number of Ph.D. students. His current research interests include physical chemistry of solutions and interfaces, electro-optic and dielectric properties of condensed media, and environmental organic chemistry.

FOOTNOTES

*Corresponding author. E-mail: prezhdo@u.washington.edu.

REFERENCES

- Hoffmann, R., *Solids and Surfaces: A Chemist's View of Bonding in Extended Structures*; VCH Publishers: New York, 1988.
- Malliaras, G.; Friend, R. An organic electronics primer. *Phys. Today* **2005**, *5*, 53–58.
- Saiz, L.; Klein, M. L. Computer simulation studies of model biological membranes. *Acc. Chem. Res.* **2002**, *35*, 482–489.
- Kamisaka, H.; Kilina, S. V.; Yamashita, K.; Prezhdo, O. V. Ultrafast vibrationally-induced dephasing of electronic excitations in a PbSe quantum dot. *Nano Lett.* **2006**, *6*, 2295–2300.
- Kilina, S. V.; Craig, C. F.; Kilin, D. S.; Prezhdo, O. V. Ab initio time-domain study of phonon-assisted relaxation of charge carriers in a PbSe quantum dot. *J. Phys. Chem. C* **2007**, *111*, 4871–4878.
- Wang, J. Real-time electrochemical monitoring: Toward green analytical chemistry. *Acc. Chem. Res.* **2002**, *35*, 811–816.
- Pereverzev, Y. V.; Prezhdo, O. V.; Forero, M.; Sokurenko, E. V.; Thomas, W. E. The two-pathway model for the catch-slip transition in biological adhesion. *Biophys. J.* **2005**, *89*, 1446–1454.
- Pereverzev, Y. V.; Prezhdo, O. V. Dissociation of biological catch-bond by periodic perturbation. *Biophys. J.* **2006**, *91*, L19–L21.
- Kilin, D. S.; Tsemekhman, K.; Prezhdo, O. V.; Zenkevich, E. I.; Borczykowski, C. v. Ab initio study of exciton transfer dynamics from a coreshell semiconductor quantum dot to a porphyrin-sensitizer. *J. Photochem. Photobiol. A* **2007**, *190*, 342–351.
- Seminario, J. M. Molecular electronics - approaching reality. *Nat. Mater.* **2005**, *4*, 111–113.
- Lewis, N. S. Frontiers of research in photoelectrochemical solar energy conversion. *J. Electroanal. Chem.* **2001**, *508*, 1–10.
- Linsebigler, A. L.; Lu, G.; Yates, J. T., Jr. Photocatalysis on TiO₂ surfaces - principles, mechanisms, and selected results. *Chem. Rev.* **1995**, *95*, 735–758.
- Sytnik, R. D.; Prezhdo, V. V.; Matveenko, V. Y.; Legoshin, G. M. Electrochemical surface treatment of glass by a lead-copper melt. *Glass Sci. Technol.* **2001**, *74*, 161–165.
- Liu, D.; Hug, G. L.; Kamat, P. V. Photochemistry on surfaces. Intermolecular energy and electron transfer processes between excited Ru(bpy)₃²⁺ and H-aggregates of cresyl violet on SiO₂ and SnO₂ colloids. *J. Phys. Chem.* **1995**, *99*, 16768–16775.
- Anderson, N. A.; Lian, T. Q. Ultrafast electron transfer at the molecule-semiconductor nanoparticle interface. *Annu. Rev. Phys. Chem.* **2005**, *56*, 491–519.
- Duncan, W. R.; Prezhdo, O. V. Theoretical Studies of Photoinduced Electron Injection from Sensitizer-Chromophores into TiO₂ Surfaces. *Annu. Rev. Phys. Chem.* **2007**, *58*, 153–184.
- Oregan, B.; Grätzel, M. A low-cost, high-efficiency solar-cell based on dye-sensitized colloidal TiO₂ films. *Nature* **1991**, *353*, 737–740.
- McConnell, R. D. Assessment of the dye-sensitized solar cell. *Renewable Sustainable Energy Rev.* **2002**, *6*, 273–293.
- Huang, S. Y.; Schlichthorl, G.; Nozik, A. J.; Grätzel, M.; Frank, A. J. Charge recombination in dye-sensitized nanocrystalline TiO₂ solar cells. *J. Phys. Chem. B* **1997**, *101*, 2576–2582.
- Tachibana, Y.; Moser, J. E.; Grätzel, M.; Klug, D. R.; Durrant, J. R. Subpicosecond interfacial charge separation in dye-sensitized nanocrystalline titanium dioxide films. *J. Phys. Chem. B* **1996**, *100*, 20056–20062.
- Hannappel, T.; Burfeindt, B.; Storck, W.; Willig, F. Measurement of ultrafast photoinduced electron transfer from chemically anchored Ru-dye molecules into empty electronic states in a colloidal anatase TiO₂ film. *J. Phys. Chem. B* **1997**, *101*, 6799–6802.
- Schwarzburg, K.; Ernstorfer, R.; Felber, S.; Willig, F. Primary and final charge separation in the nano-structured dye-sensitized electrochemical solar cell. *Coord. Chem. Rev.* **2004**, *248*, 1259–1270.
- Ghosh, H. N.; Asbury, J. B.; Lian, T. Q. Direct observation of ultrafast electron injection from coumarin 343 to TiO₂ nanoparticles by femtosecond infrared spectroscopy. *J. Phys. Chem. B* **1998**, *102*, 6482–6486.
- Asbury, J. B.; Hao, E. C.; Wang, Y. Q.; Ghosh, H. N.; Lian, T. Q. Ultrafast electron transfer dynamics from molecular adsorbates to semiconductor nanocrystalline thin films. *J. Phys. Chem. B* **2001**, *105*, 4545–4557.
- Anderson, N. A.; Lian, T. Q. Ultrafast electron injection from metal polypyridyl complexes to metal-oxide nanocrystalline thin films. *Coord. Chem. Rev.* **2004**, *248*, 1231–1246.
- Huber, R.; Spoerlein, S.; Moser, J. E.; Grätzel, M.; Wachtveitl, J. The role of surface states in the ultrafast photoinduced electron transfer from sensitizing dye molecules to semiconductor colloids. *J. Phys. Chem. B* **2000**, *104*, 8995–9003.
- Huber, R.; Moser, J. E.; Grätzel, M.; Wachtveitl, J. Real-time observation of photo-induced adiabatic electron transfer in strongly coupled dye/semiconductor colloidal systems with a 6 fs time constant. *J. Phys. Chem. B* **2002**, *106*, 6494–6499.
- Matylytsky, V. V.; Lenz, M. O.; Wachtveitl, J. Observation of pH-dependent back-electron-transfer dynamics in alizarin/TiO₂ adsorbates: Importance of trap states. *J. Phys. Chem. B* **2006**, *110*, 8372–8379.
- Watson, D. F.; Meyer, G. J. Electron injection at dye-sensitized semiconductor electrodes. *Annu. Rev. Phys. Chem.* **2005**, *56*, 119–156.
- Zhang, D. S.; Downing, J. A.; Knorr, F. J.; McHale, J. L. Room-temperature preparation of nanocrystalline TiO₂ films and the influence of surface properties on dye-sensitized solar energy conversion. *J. Phys. Chem. B* **2006**, *110*, 21890–21898.
- Ramakrishna, S.; Willig, F.; May, V. Theory of ultrafast photoinduced heterogeneous electron transfer: Decay of vibrational coherence into a finite electronic-vibrational quasicontinuum. *J. Chem. Phys.* **2001**, *115*, 2743–2756.
- Ramakrishna, S.; Willig, F.; May, V.; Knorr, A. Femtosecond spectroscopy of heterogeneous electron transfer: Extraction of excited-state population dynamics from pump-probe signals. *J. Phys. Chem. B* **2003**, *107*, 607–611.
- Wang, L. X.; Willig, F.; May, V. Ultrafast heterogeneous electron transfer reactions: Comparative theoretical studies on time- and frequency-domain data. *J. Chem. Phys.* **2006**, *124*, 014712.
- Thoss, M.; Kondov, I.; Wang, H. Theoretical study of ultrafast heterogeneous electron transfer reactions at dye-semiconductor interfaces. *Chem. Phys.* **2004**, *304*, 169–181.
- Kondov, I.; Thoss, M.; Wang, H. Theoretical study of ultrafast heterogeneous electron transfer reactions at dye-semiconductor interfaces: Coumarin 343 at titanium oxide. *J. Phys. Chem. A* **2006**, *110*, 1364–1374.
- Rego, L. G. C.; Batista, V. S. Quantum dynamics simulations of interfacial electron transfer in sensitized TiO₂ semiconductors. *J. Am. Chem. Soc.* **2003**, *125*, 7989–7997.

- 37 Abuabara, S. G.; Rego, L. G. C.; Batista, V. S. Influence of thermal fluctuations on interfacial electron transfer in functionalized TiO₂ semiconductors. *J. Am. Chem. Soc.* **2005**, *127*, 18234–18242.
- 38 Stier, W.; Prezhdo, O. V. Nonadiabatic molecular dynamics simulation of light-induced, electron transfer from an anchored molecular electron donor to a semiconductor acceptor. *J. Phys. Chem. B* **2002**, *106*, 8047–8054.
- 39 Stier, W.; Prezhdo, O. V. Thermal effects in the ultrafast photoinduced electron transfer from a molecular donor anchored to a semiconductor acceptor. *Isr. J. Chem.* **2003**, *42*, 213–224.
- 40 Stier, W.; Duncan, W. R.; Prezhdo, O. V. Thermally assisted sub-10 fs electron transfer in dye-sensitized nanocrystalline TiO₂ solar cells. *Adv. Mater.* **2004**, *16*, 240–244.
- 41 Duncan, W. R.; Stier, W. M.; Prezhdo, O. V. Ab initio nonadiabatic molecular dynamics of the ultrafast electron injection across the alizarin-TiO₂ interface. *J. Am. Chem. Soc.* **2005**, *127*, 7941–7951.
- 42 Duncan, W. R.; Prezhdo, O. V. Nonadiabatic molecular dynamics study of electron transfer from alizarin to the hydrated Ti⁴⁺ ion. *J. Phys. Chem. B* **2005**, *109*, 17998–18002.
- 43 Duncan, W. R.; Craig, C. F.; Prezhdo, O. V. Time-domain ab initio study of charge relaxation and recombination in dye-sensitized TiO₂. *J. Am. Chem. Soc.* **2007**, *129*, 8528–8543.
- 44 Diebold, U. The surface science of titanium dioxide. *Surf. Sci. Rep.* **2003**, *48*, 53–229.
- 45 Odelius, M.; Persson, P.; Lunell, S. Bi-isonicotinic acid on rutile (110): calculated molecular and electronic structure. *Surf. Sci.* **2003**, *529*, 47–58.
- 46 Argazzi, R.; Iha, N. Y. M.; Zabri, H.; Odobel, F.; Bignoz, C. A. Design of molecular dyes for application in photoelectrochemical and electrochromic devices based on nanocrystalline metal oxide semiconductors. *Coord. Chem. Rev.* **2004**, *248*, 1299–1316.
- 47 Pedash, Y. F.; Prezhdo, O. V.; Kotelevskiy, S. I.; Prezhdo, V. V. Spin-orbit coupling and luminescence characteristics of conjugated organic molecules. I. Polyacenes. *Theochem* **2002**, *585*, 49–59.
- 48 Ramakrishna, S.; Willig, F.; Knorr, A. Photoinduced bulk-surface dynamics: time resolved two photon photoemission signals at semiconductor surfaces. *Surf. Sci.* **2004**, *558*, 159–173.
- 49 Fisher, A. C.; Peter, L. M.; Ponomarev, E. A.; Walter, A. B.; Wijayantha, K. G. U. Intensity dependence of the back reaction and transport of electrons in dye-sensitized nanocrystalline TiO₂ solar cells. *J. Phys. Chem. B* **2000**, *104*, 949–958.
- 50 Prezhdo, V. V.; Tarasova, G. V.; Prezhdo, O. V.; Tyurin, S. A.; Ivanov, N. I.; Kurskaya, T. N. Electric polarization of Onsager fluids. 1. Dipole polarization. 3. The role of universal interactions. *Acta Phys. Pol., A* **1995**, *88*, 419–434.
- 51 Brooksby, C.; Prezhdo, O. V.; Reid, P. J. Molecular dynamics study of the weakly solvent dependent relaxation dynamics following chlorine dioxide photoexcitation. *J. Chem. Phys.* **2003**, *119*, 9111–9120.
- 52 Kondov, I.; Thoss, M.; Wang, H. Computational study of titanium (IV) complexes with organic chromophores. *Int. J. Quantum Chem.* **2006**, *106*, 1291–1303.
- 53 Craig, C. F.; Duncan, W. R.; Prezhdo, O. V. Trajectory surface hopping in the time-dependent Kohn-Sham approach for electron-nuclear dynamics. *Phys. Rev. Lett.* **2005**, *95*, 163001.
- 54 Drukker, K. Basics of surface hopping in mixed quantum/classical simulations. *J. Comput. Phys.* **1999**, *153*, 225–272.
- 55 Prezhdo, O. V. Quantized hamilton dynamics. *Theor. Chem. Acc.* **2006**, *116*, 206–218.